



US
o.D.Tubing

NAUE GmbH

Sondermaschinen - und Filterbau

Am Rotböhl 5
64331 Weiterstadt
www.naue.de

Tel. 0 61 50 / 97 38 - 0
Fax. 0 61 50 / 70 18
Info@naue.de

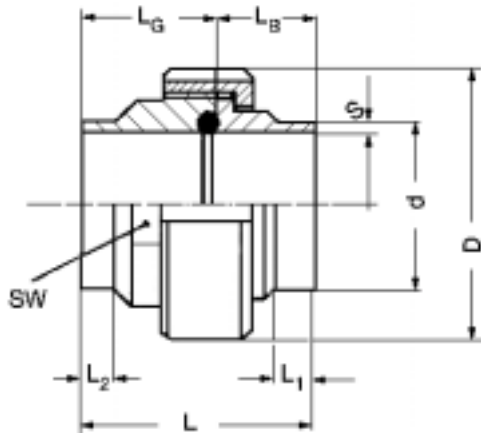

Sterilverschraubung

Material	Gewindestutzen	1.4404 / 316 L
	Bundstutzen	1.4404 / 316 L
	Mutter	1.4301 / 304

Andere Werkstoffe und Abmessungen auf Anfrage

STANDARD-SCHWEISS-AUSFÜHRUNG

metrisches Gewinde											Rundgewinde	
DN	d ISO	D	L	L ₁	L ₂	I _B	L _G	SW	O-Ring	Bestell-Nr.	D	Bestell-Nr.
¼	6,35 x 1,22	SW 17	33	6	5	15	18	8	4,0 x 2,0	05-15001		05-19001
⅜	9,53 x 1,22	SW 22	33	6	5	15	18	13	7,5 x 2,5	05-15003		05-19003
½	12,70 x 1,65	SW 27	33	6	5	15	18	17	10,0 x 2,5	05-15005		05-19005
¾	19,05 x 1,65	SW 36	36	6	5	16	20	22	16,3 x 3,0	05-15007		05-19007
1	25,40 x 1,65	Ø 48	40	6	5	18	22		22,0 x 3,0	05-15009		05-19009
1 ½	38,10 x 1,65	Ø 62	45	12	6	21	24		36,0 x 3,0	05-15011		05-19011
2	50,80 x 1,65	Ø 76	47	12	6	22	25		48,0 x 3,0	05-15013		05-19013
2 ½	63,50 x 1,65	Ø 95	70	12	12	31	39		61,0 x 4,0	05-15015		05-19015
3	76,20 x 1,65	Ø 105	70	12	12	31	39		74,0 x 4,0	05-15017		05-19017
4	101,60 x 2,10	Ø 140	70	12	12	31	39		100,0 x 5,0	05-15019		05-19019

UNIVERSAL-ORBITAL-SCHWEISS-AUSFÜHRUNG

Metrisches Gewinde											Rundgewinde	
DN	d ISO	D	L	L ₁	L ₂	I _B	L _G	SW	O-Ring	Bestell-Nr.	D	Bestell-Nr.
¼	6,35 x 1,22	SW 17	33	16	16	25	28	8	4,0 x 2,0	05-15025		05-19025
⅜	9,53 x 1,22	SW 22	33	16	16	25	28	13	7,5 x 2,5	05-15027		05-19027
½	12,70 x 1,65	SW 27	33	16	16	25	28	17	10,0 x 2,5	05-15029		05-19029
¾	19,05 x 1,65	SW 36	36	16	16	25	28	22	16,3 x 3,0	05-15031		05-19031
1	25,40 x 1,65	Ø 48	40	16	16	25	28		22,0 x 3,0	05-15033		05-19033
1 ½	38,10 x 1,65	Ø 62	45	16	16	26	32		36,0 x 3,0	05-15035		05-19035
2	50,80 x 1,65	Ø 76	47	16	16	26	32		48,0 x 3,0	05-15037		05-19037
2 ½	63,50 x 1,65	Ø 95	70	16	16	31	44		61,0 x 4,0	05-15039		05-19039
3	76,20 x 1,65	Ø 105	70	16	16	31	44		74,0 x 4,0	05-15041		05-19041
4	101,60 x 2,10	Ø 140	70	16	16	45	58		100,0 x 5,0	05-15043		05-19043

Änderungen vorbehalten